



**IE-SOAR™**

Powering the hydrogen future™



Fly  
longer



Fly  
further

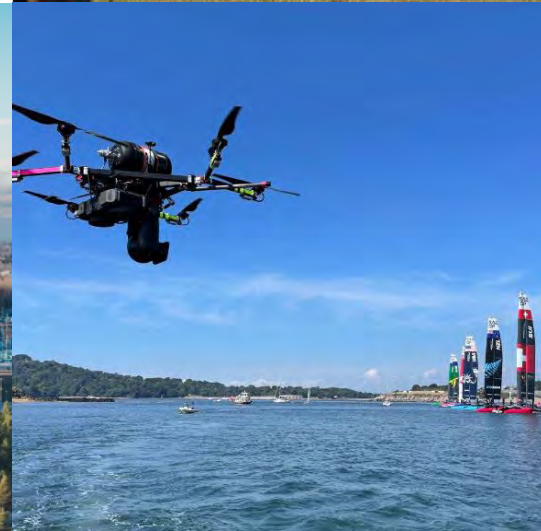

Achieve  
more

# IE-SOAR Fuel Cells

**IE-SOAR fuel cell systems replace your battery and unlock long endurance flight.**

IE-SOAR™ is our range of lightweight hydrogen fuel cell modules for fixed wing, rotary wing and VTOL UAV applications, our systems unchain UAVs from the restrictive flight times offered by current battery technology.

IE-SOAR benefits:

✓ **Direct battery replacement (6S to 16S compatible)**  
Automatically follows load demand just like a battery.

✓ **Designed for safety and reliability**  
Single point failure tolerant and with built in power system redundancy.

✓ **Modular**  
Combine systems in parallel to increase outputs to 24kW.

By replacing the battery with a fuel cell power module you can maximise productivity and minimise downtime meaning you can **fly longer, fly further and achieve more.**

**Enable previously impossible applications**  
– your business is no longer constrained by flight time.

**Unlock BVLOS operations**  
– Beyond Visual Line of Sight (BVLOS) makes sense with the range provided by fuel cells.

**Increase operational efficiency**  
– spend 3x longer in the air and achieve more.

**Lower cost per flight hour**  
– at volume, fuel cells are cheaper than batteries.



Longer  
flight time  
compared to batteries

Less  
downtime  
with rapid refueling

Increase  
productivity  
a one-stop solution

Zero-emission  
flight

Fast refuelling

Increased  
flight time



# Our SOAR product range

## IE-SOAR™ 800

Maximum continuous power:	800W
Peak power (with hybrid battery):	2400W
Module mass:	1450g
Direct battery replacement:	6S to 12S compatible
VTOL and fixed wing applications	
Surveillance, inspection, surveying, mapping	
Can be operated in parallel to achieve up to 6400W	

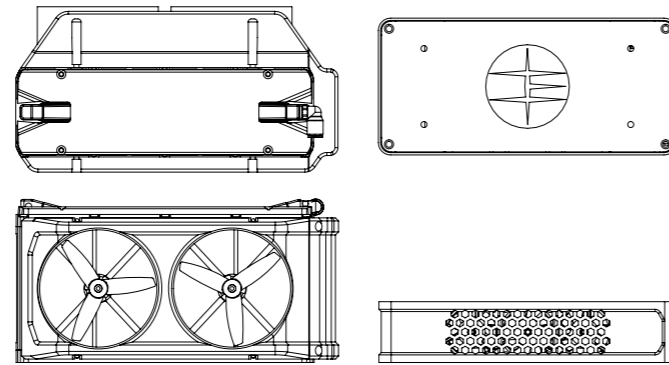

## IE-SOAR™ 1.2

Maximum continuous power:	1.2kW
Peak power (with hybrid battery):	8kW
Module mass:	2700g
Direct battery replacement:	12S to 16S compatible
Multi-rotor, fixed wing and proprietary designed UAV applications	
Surveillance, inspection, surveying, mapping	
Can be operated in parallel to achieve up to 9.6kW	

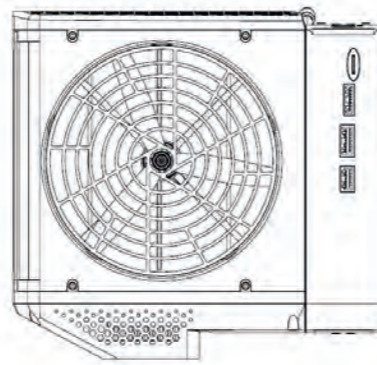

## IE-SOAR™ 2.4

Maximum continuous power:	2.4kW
Peak power (with hybrid battery):	8kW
Module mass:	4800g
Direct battery replacement:	12S to 16S compatible
Fixed wing, rotary wing and VTOL UAV applications	
Surveillance, inspection, surveying, mapping, parcel delivery	
Can be operated in parallel to achieve up to 24kW	

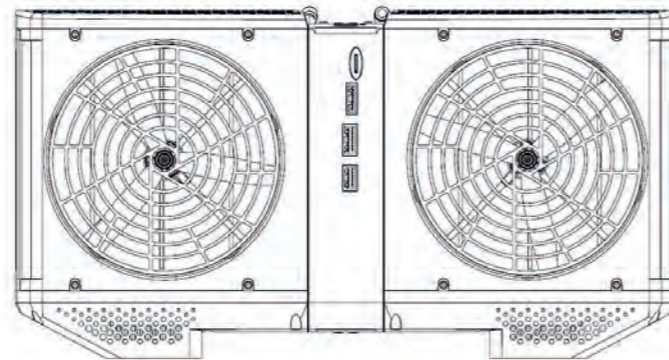

# Applications



## LINEAR INSPECTION SHELL

Unlock the range that makes sense for BVLOS operations. The longer flight range enabled by fuel cells equals less downtime and increased efficiency. Operations totaling to a fraction of the cost of a manned helicopter equivalent. Chosen by Shell to inspect pipelines BVLOS.



## CINEMATOGRAPHY SAIL GP

Film the whole event in one flight. Stay in the air for the entire broadcast window. UAVs are heavily used in the film industry, but the need to land and recharge means important footage can be missed. Fuel cells enable you to stay in the air for longer with less downtime and continuous footage.



## PARCEL DELIVERY H2C

Compared with batteries, fuel cell powered UAVs have a higher range, resulting in more serviceable customers and a longer life, resulting in lower TCO. Generate your own fuel from clean energy and refill in minutes. Improved operational efficiency.



## LIDAR AND MAPPING KELLUU

Map larger environments thanks to reduced maintenance and downtime. With fewer stops to refuel, UAVs spend longer periods in the air. This means fewer calibration runs and more efficient operations.



## MILITARY ISR AURORA FLIGHT SCIENCES

Longer range and longer flight time equals higher quality data, better situational awareness and geospatial intelligence.

# IE-SOAR Fuel Cell System Components

What you need to fly (all parts can be supplied by Intelligent Energy)

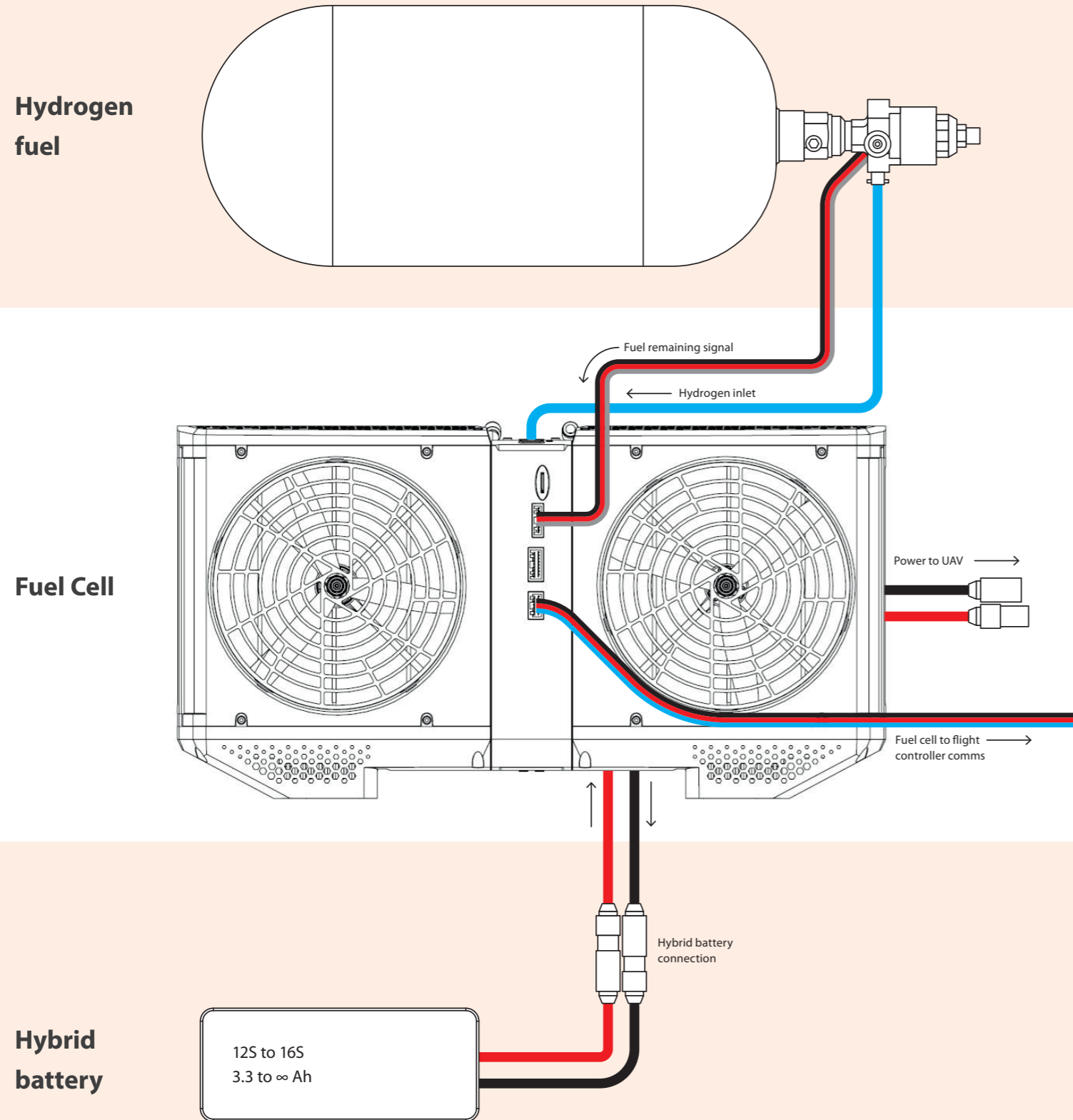

- Single stage lightweight regulator up to 350 bar inlet
- Fast refuel or cylinder swap
- Accurate fuel level reading
- Range of certified hydrogen cylinders available
- Range of refill options available

- Typical 2000-hour product life
- Direct battery replacement system
- Single point failure tolerant
- 800W and 3kW fuel cells available
- Modular and configurable design to fit most power requirements
- Our fuel cells are natively supported by the Ardupilot flight controller software
- System integration support from dedicated team

Payload vs Flight Time with different cylinder options

Typical 25kg Rotary Wing

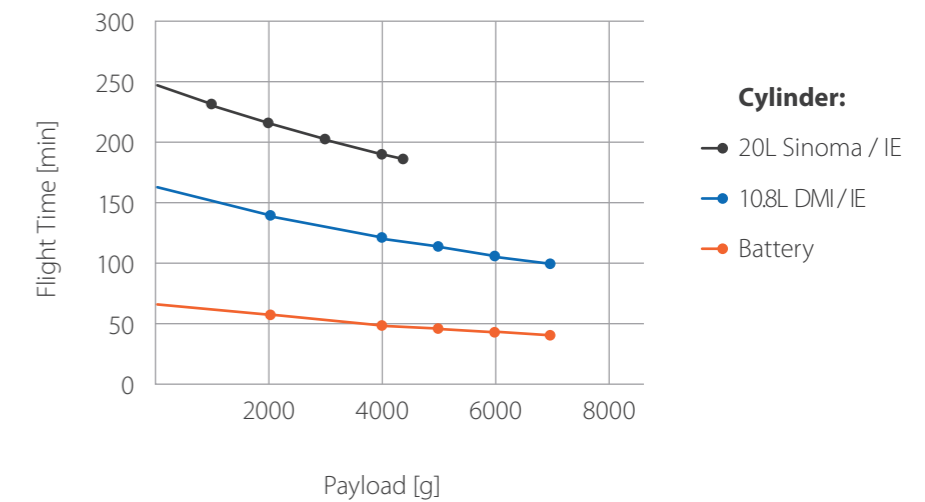

## Hybridisation = best of both technologies

Peak Power (>3000W) will come from the hybrid battery

While load is less than 3000W, hybrid batteries can be **recharged in flight.**

Hybrid battery cannot be switched out of the circuit, meaning it also acts as **power system redundancy.**

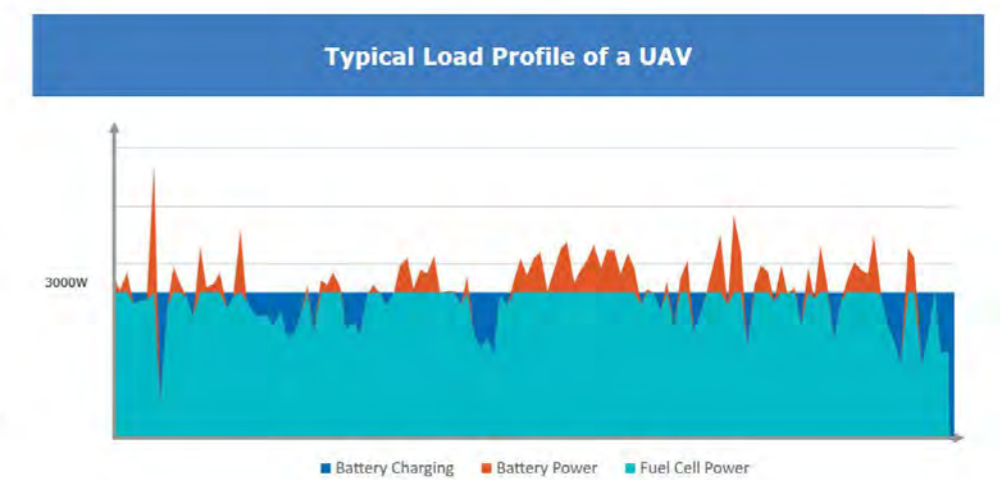

# Example Integrations



## CELLEN H2-6

A rotary wing drone powered by the IE-SOAR 2.4kW system. Up to 125 min flight time with a 4 lb payload.

Designed & built in the USA, the H2-6 meets all NDAA and FAA requirements.



## ZEPHER FLIGHT LABS Z1 VTOL

A Group 2 UAS with significantly better endurance and payload capacity than other Group 2 electric aircraft. Also offers low noise signature, rapid deployment and military supply chain.



## SKYCUTTER SC GRYPHON

120 minutes flight time with 5kg payload at 23kg take-off weight. 7kg payload for 90 minutes at 25kg. All OTS components and built in power system redundancy.



## UNMANNED AEROSPACE GH-4

Efficient gyrocopter platform powered by the IE-SOAR 2.4kW. Extremely low noise signature and designed to fly over water. Naval logistics, ISR (intelligence, surveillance, and reconnaissance) and coast guard applications.



## AURORA SKIRON XLE

Fixed wing VTOL aircraft under 25kg that can fly over 7 hours. Aimed at commercial and defence customers, in particular LRR (Long Range Reconnaissance).



## KELLUU AIRSHIP

Lighter-than-air ship with proven operational flight below -30C. Silent, certified for flight in urban environments and long endurance for massive area coverage.

Replace your battery and unlock long endurance flight



## Who are we?

Since 2001, Intelligent Energy has been dedicated to building a successful hydrogen fuel cell manufacturing business focused on the development, of its lightweight, high efficiency, fuel cell systems.

The fuel cells range from sub-1kW to 100kW+ for demanding applications across automotive, aerospace, power generation, telecoms, unmanned aerial vehicles and material handling equipment.

## Where are we?

Our headquarters and manufacturing are based in the UK, with our systems being used by our partners and customers worldwide.

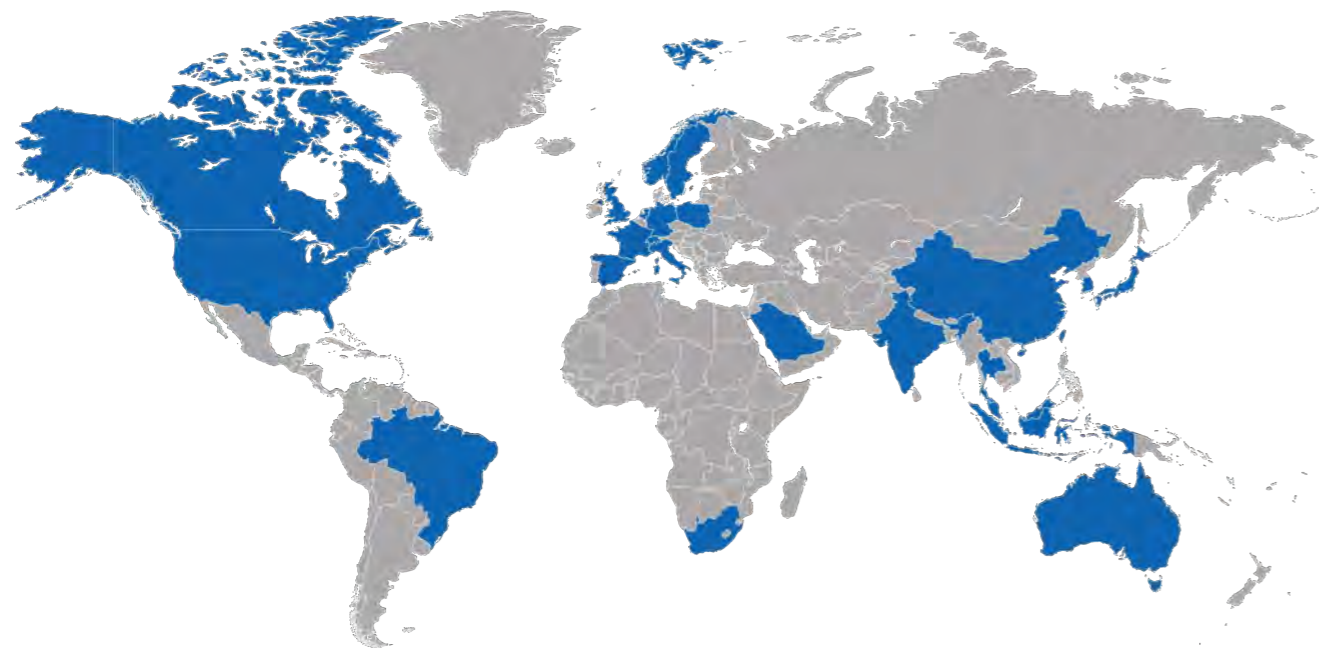

### **Intelligent Energy Headquarters**

Charnwood Building, Holywell Park. Ashby Road, Loughborough. LE11 3GB. United Kingdom

Increase  
operational  
efficiency and  
unlock BVLOS  
operations

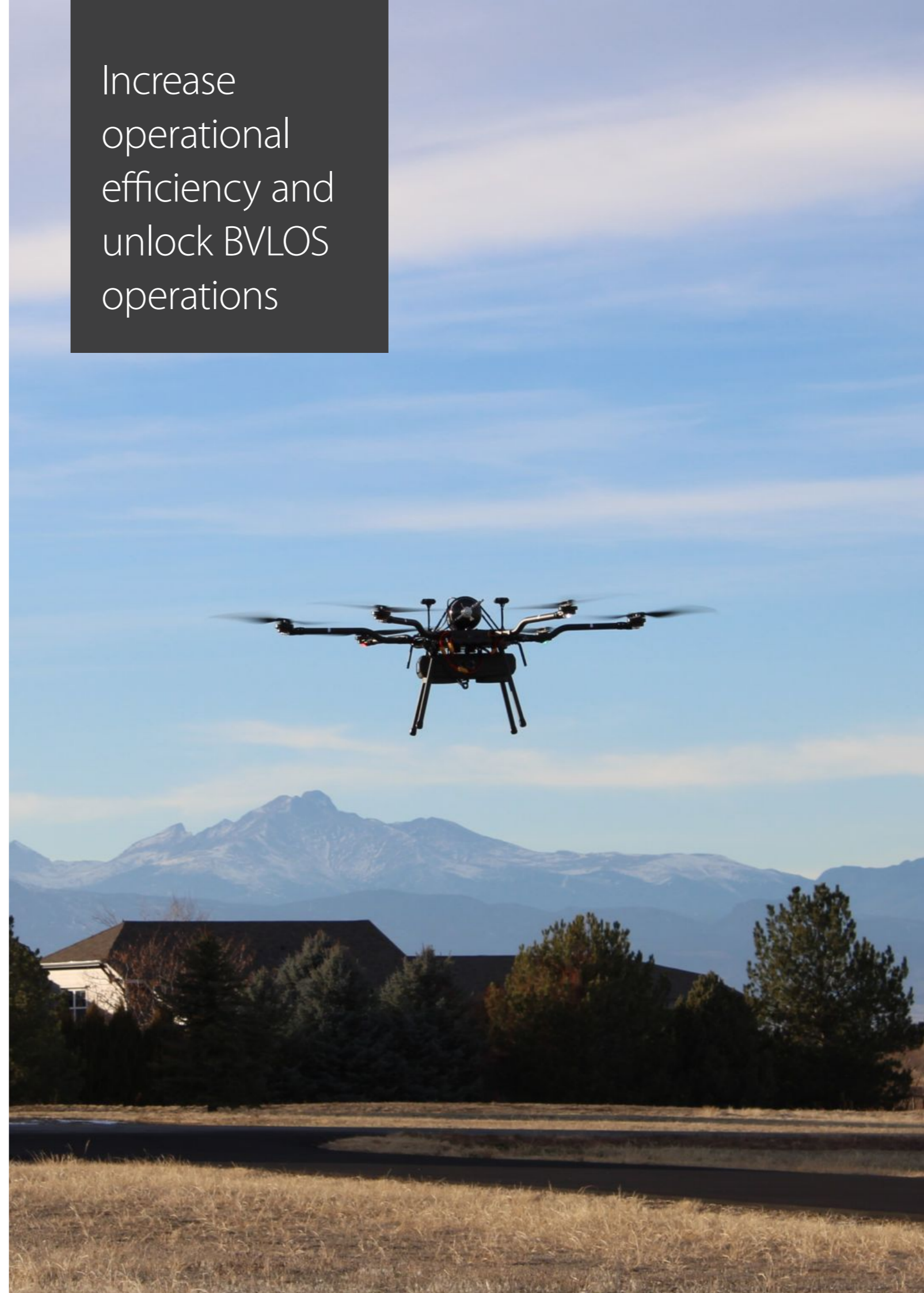



Powering the hydrogen future™

**[www.intelligent-energy.com](http://www.intelligent-energy.com)**

© Intelligent Energy Limited 2024. The Intelligent Energy name, logo, and other trade brands/names referenced herein are trademarks or registered trademarks of Intelligent Energy Ltd or its group companies, whether or not they are used with trademark symbol "TM" or "®".

Disclaimer: The information contained in this publication is intended only as a guide and is subject to change as a result of the constant evolution of Intelligent Energy's business and its technology. This publication and its contents (i) are not definitive or contractually binding; (ii) do not include all details which may be relevant to particular circumstances; and (iii) should not be regarded as being a complete source of information. To the fullest extent permitted by law, Intelligent Energy offers no warranty as to the accuracy of the content of this publication, shall not be liable for the content of this publication and no element of this publication shall form the basis of any contractual relationship with a third party or be used by any third party as the basis for its decision to enter into a contractual relationship with Intelligent Energy. Published by: Intelligent Energy Ltd, Charnwood Building, Holywell Park, Ashby Road, Loughborough LE11 3GB (Registered in England with company number: 03958217). Printed March 2024. All information correct at time of going to print. 75984-IE-BR-202304