

Powering the hydrogen future™

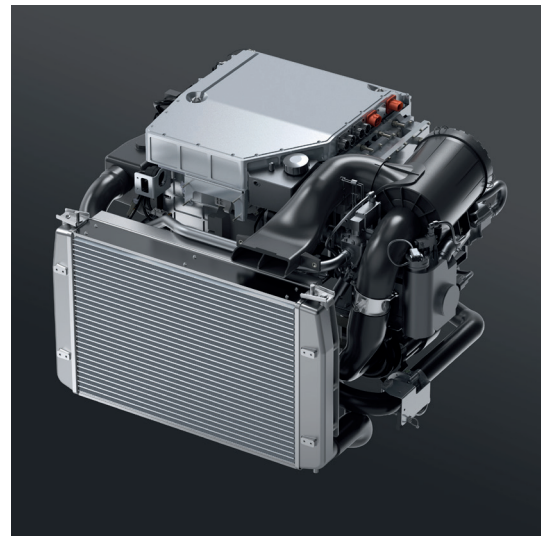

Zero  
emission



High  
power  
density



Modular  
Scalable

# Why fuel cells for automotive?

Our fuel cell technology is particularly suitable for long-range buses and heavy-duty trucks where BEV technology struggles to provide enough range.

For passenger vehicles, the fast refueling and lower weight of our fuel cells also help with applications such as large SUVs and taxis where batteries are too slow to recharge and too heavy to be viable.

- **More range with less weight** – fuel cells are lighter than batteries, so longer range can be provided practically and efficiently.
- **Work like an ICE vehicle** – fuel cell vehicles have large fuel tanks that refill in minutes at public filling stations, no need to change the way that people use their cars or trucks.
- **Sustainability & supply chain** – fuel cells are 95% recyclable; batteries have a significant carbon life cycle footprint and reduced recyclability.
- **No electrical charging** – reduces the impact on the electrical grid from mass vehicle charging.

## Benefits

Lighter

Less balance of plant

High specific power

Easy integration

Market ready

Modular

Proven technology

Long life span



Automotive applications



# IE-DRIVE Fuel Cells

**High power, lightweight, modular fuel cells for automotive, heavy duty and stationary use.**

IE-DRIVE™ is Intelligent Energy's (IE) latest high-power hydrogen fuel cell system. Utilising our patented direct water injection technology, our fuel cells for automotive and stationary applications deliver compact, modular systems with fewer components, improved reliability, and reduced system costs.

**IE have developed two versions of the IE-DRIVE, using the same core fuel cell stack technology.**

**IE-DRIVE HD100** is our heavy-duty fuel cell which is a one-box design ideal for buses, trucks, stationary power and off-highway applications.

**IE-DRIVE 100** is designed for passenger cars and light commercial vehicles, a modular design providing maximum flexibility for installation and best in class power density.

IE-DRIVE benefits:

- ✓ **30% smaller** heat exchanger
- ✓ **High power** density
- ✓ **Compact** and easy to integrate
- ✓ Unique **patented airflow** management
- ✓ **Modular**

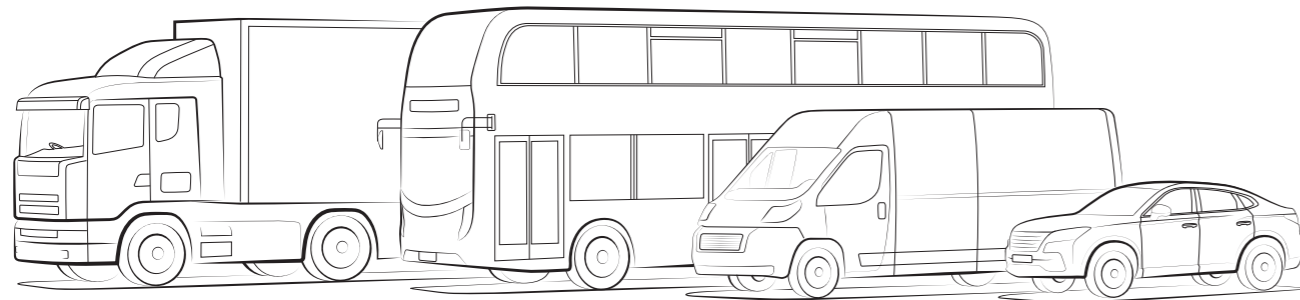

30%

smaller heat exchanger

High specific  
power

Easy  
integration  
Scalable and modular

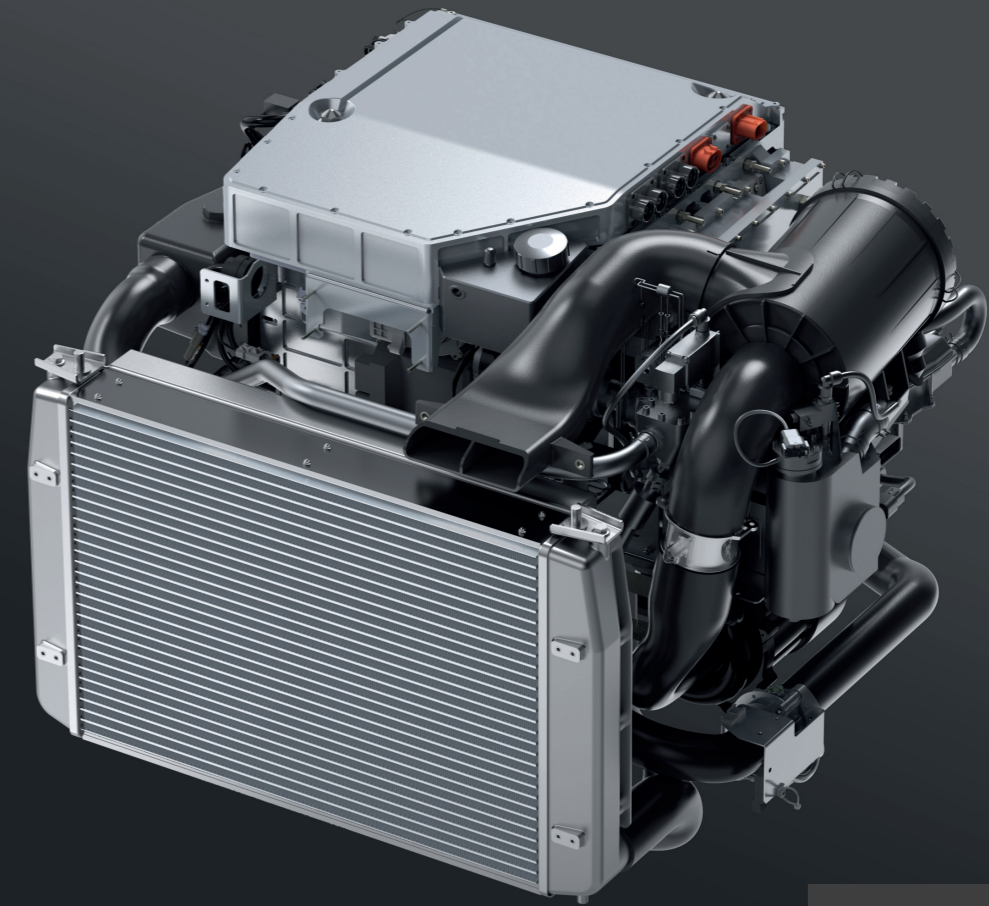

IE-DRIVE 100

Passenger cars  
Light commercial vehicles

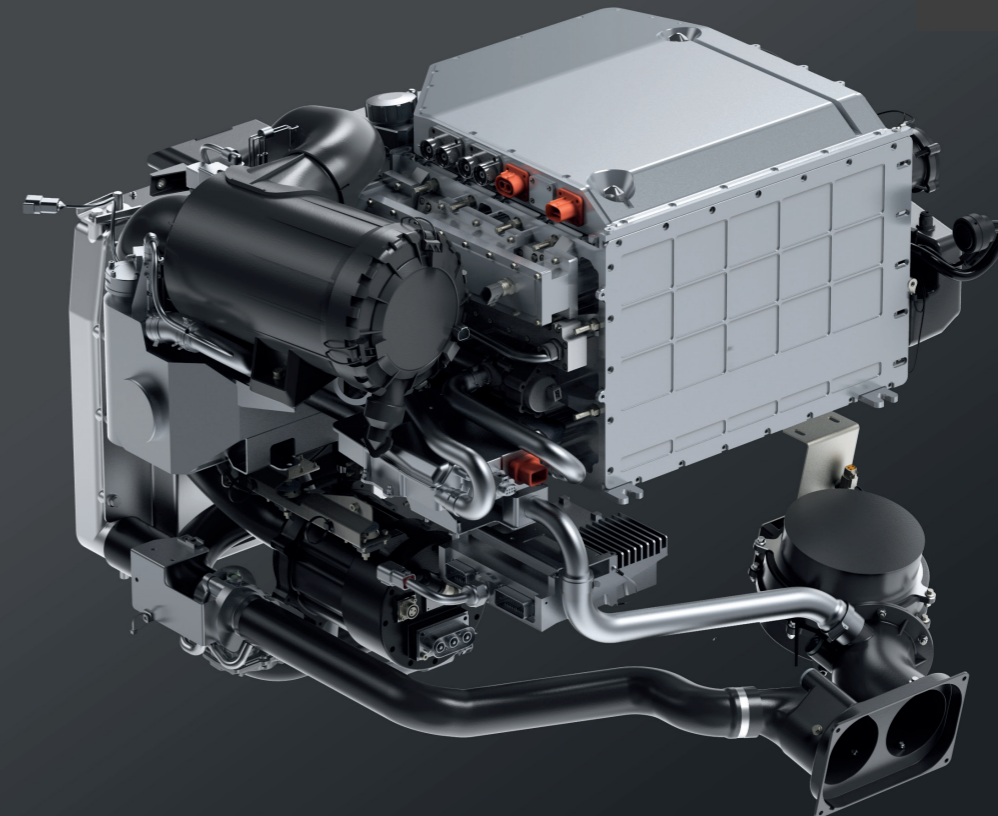

# Our DRIVE Product Range

## IE-DRIVE™ HD100

Through life power:	100kW
Module mass:	250kg
Dimensions:	1260mm (W) × 520mm (H) × 700mm
Heavy-duty, modular, easy to integrate, long life	
Buses, trucks, rail, marine, construction and stationary power applications	

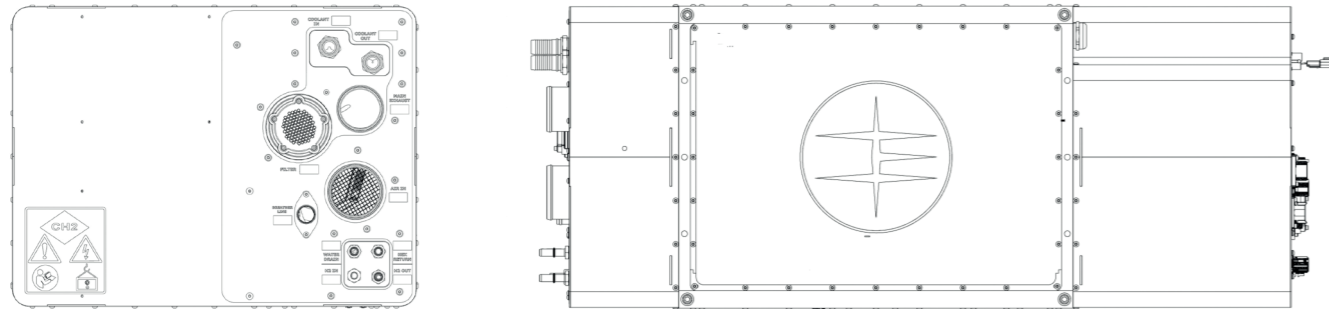

## IE-DRIVE™ 100

Peak power:	110kW
Module mass:	240kg
Best in class power density	
Passenger cars and light commercial vehicles	

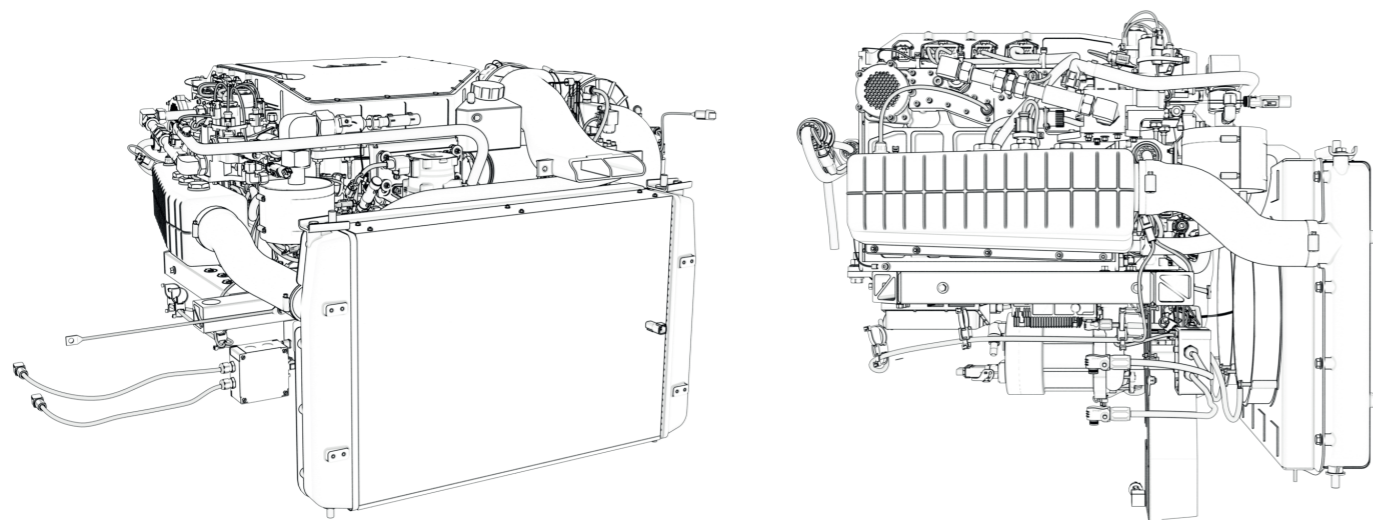

# Applications



## PASSENGER CARS Changan UK

Working with Changan's UK R&D Centre, Intelligent Energy is developing high specific power fuel cell for passenger vehicle.

The IE-DRIVE 100 system was installed into a Changan SUV in 2023.



## BUSES Alexander Dennis

Intelligent Energy and Alexander Dennis are partners in the UK funded project ESTHER.

The project is looking at the integration of fuel cells into buses and aim at establishing a UK fuel-cell production for large passenger cars, buses and heavy-duty transport.



## TRUCKS MIRA/Viritech

Intelligent Energy are working with HORIBA MIRA, leading European automotive engineering and testing consultancy, and Viritech, the leading developer of high-performance hydrogen powertrain solutions for the automotive industry to develop technologies suitable for a 40-tonne hydrogen fuel cell electric vehicle.



## STATIONARY POWER Hogreen

Intelligent Energy and Hogreen Air signed an agreement for the delivery of IE-DRIVE HD100 fuel cell systems from 2024 for a 10MW power station.

Final assembly will be completed in a new facility in South Korea

# System Integration

Our automotive products have been designed to easily be integrated into the end product, taking the complexity out for the customer.

The IE-DRIVE is a complete system with the full balance of plant including the stack module, the air and hydrogen systems, the control unit and is provided with the complete heat exchanger.

The **IE-DRIVE HD100** is designed as a 'plug and play' complete system and can easily fit on the side of trucks or under the driver's cabin. For stationary power generation it has been successfully integrated into containerised systems.

With a more compact stack module, the **IE-DRIVE 100** is designed to fit under the bonnet of passenger cars, SUVs and light commercial vehicles.

The balance of plant can also be co-developed to suit the customer's specific needs.

Intelligent Energy's patented direct water injection technology means DRIVE's heat exchanger is up to 30% smaller than its competitors at equal net power output.

IE-DRIVE™ HD100 scope of supply:

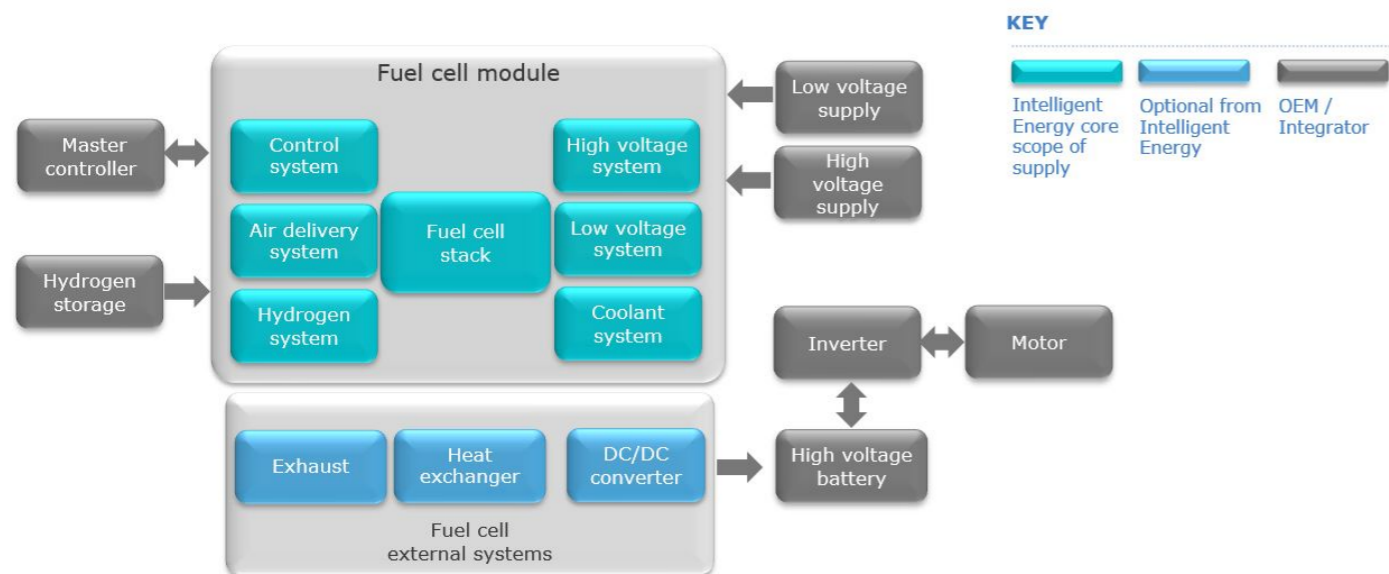

IE-DRIVE™ 100 scope of supply:

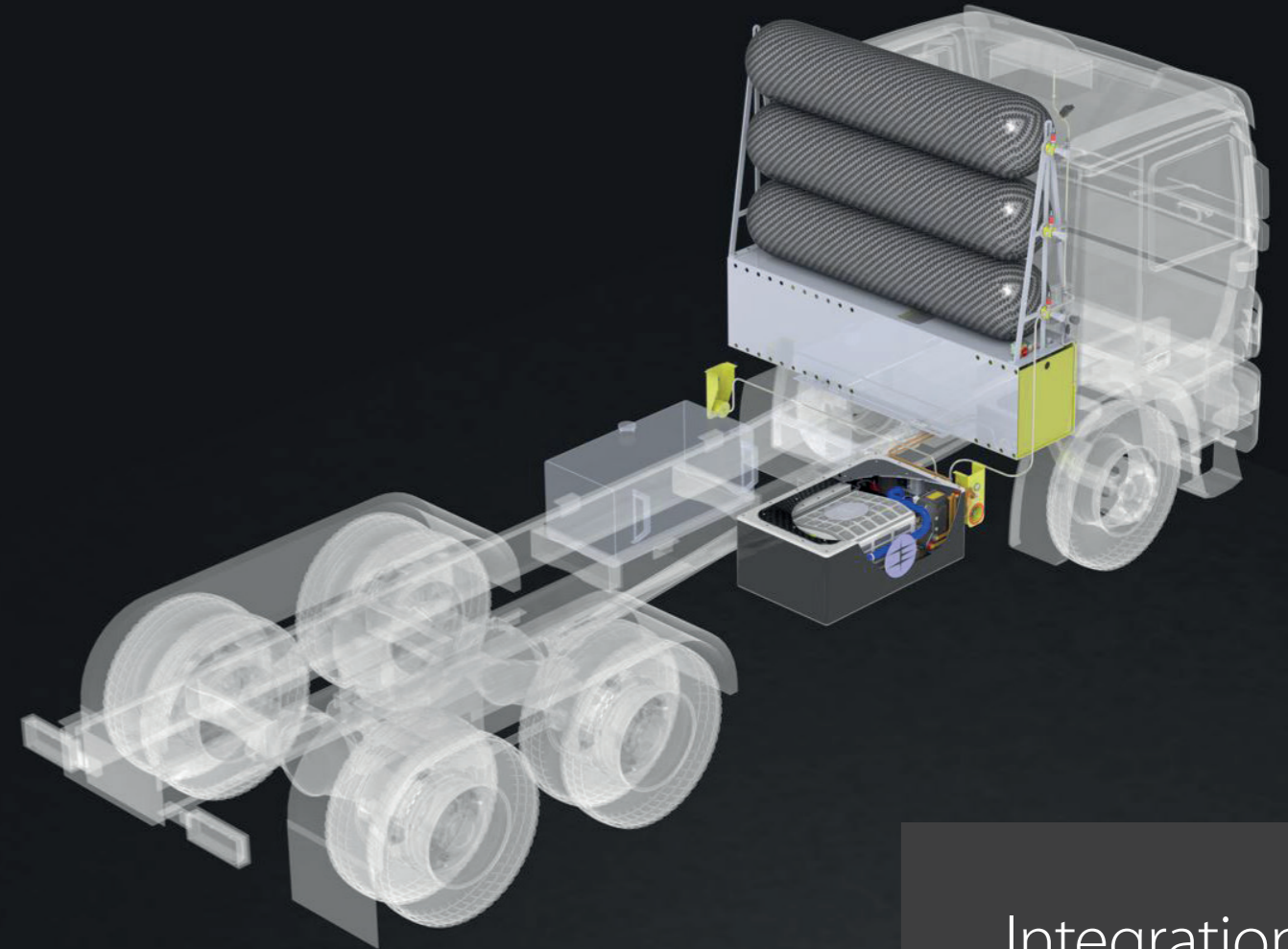
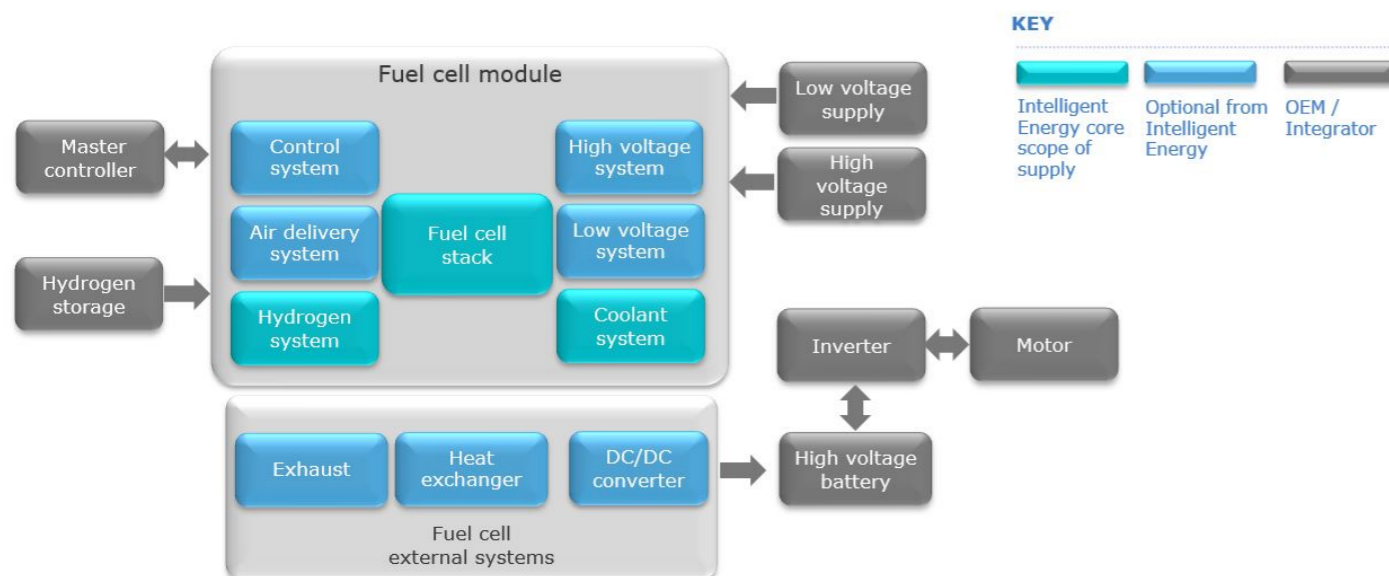

Integration examples

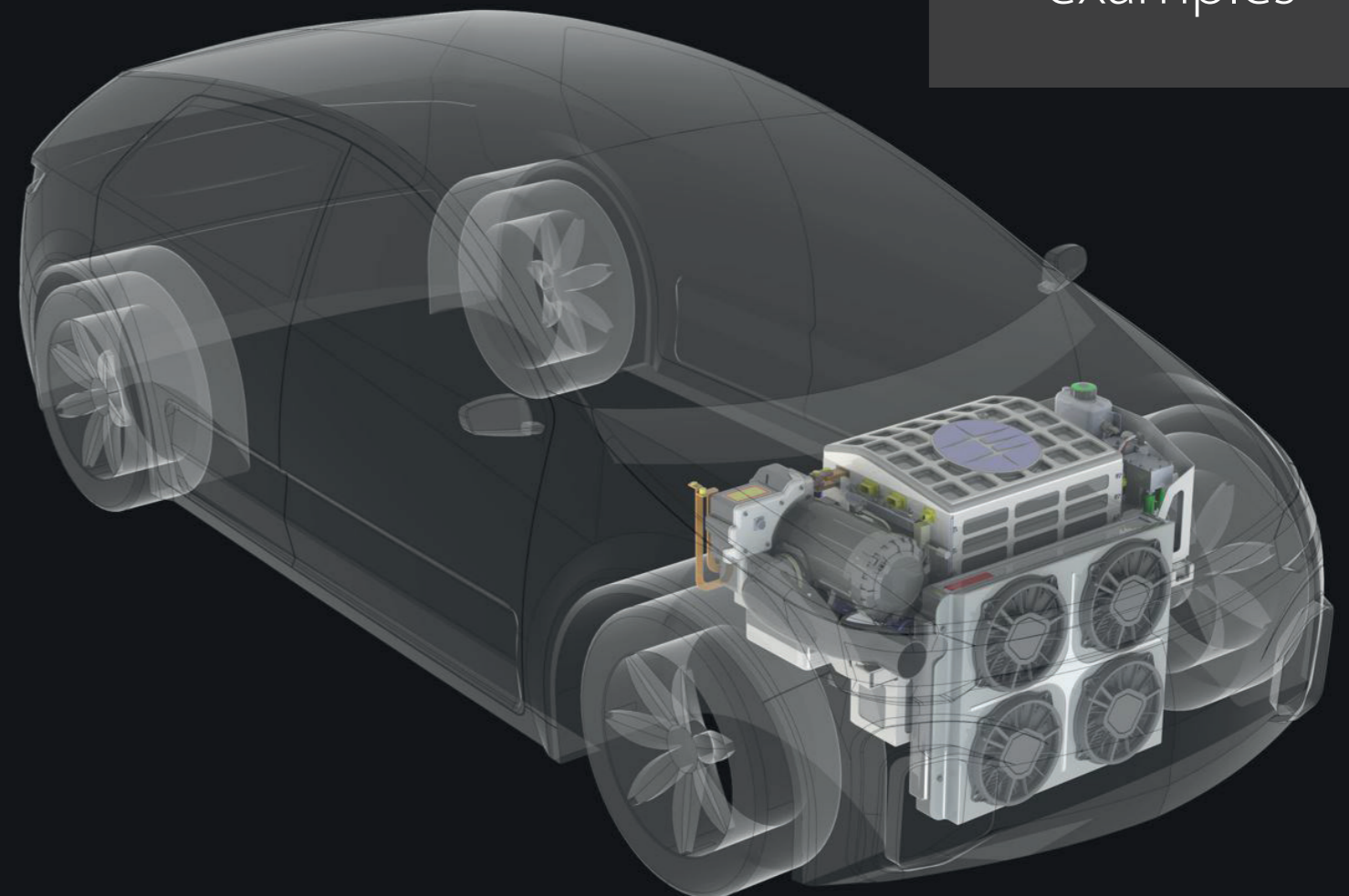

# Who are we?

Since 2001, Intelligent Energy has been dedicated to building a successful hydrogen fuel cell manufacturing business focused on the development, of its lightweight, high efficiency, fuel cell systems.

The fuel cells range from sub-1kW to 100kW+ for demanding applications across automotive, aerospace, power generation, telecoms, unmanned aerial vehicles and material handling equipment.

# Where are we?

Our headquarters and manufacturing are based in the UK, with our systems being used by our partners and customers worldwide.

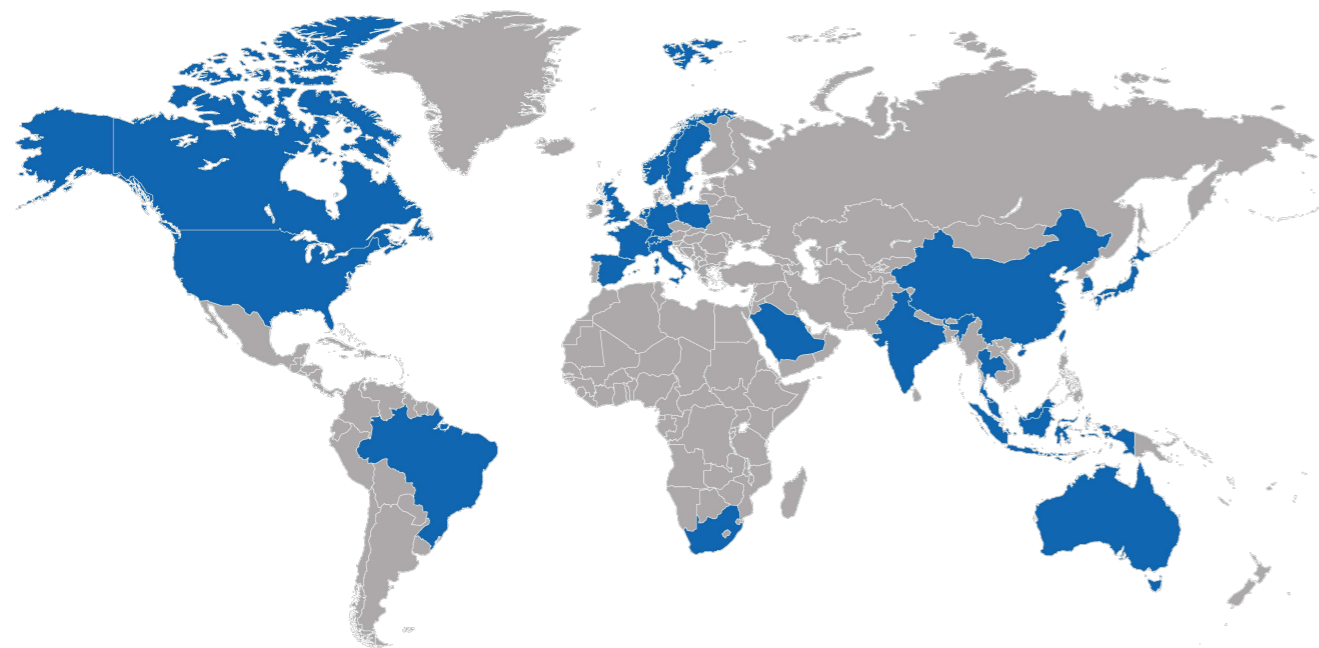

## Intelligent Energy Headquarters

Charnwood Building, Holywell Park, Ashby Road, Loughborough. LE11 3GB. United Kingdom



## IE-DRIVE HD100

Heavy duty  
Buses, trucks  
Stationary power



## Powering the hydrogen future™

**[www.intelligent-energy.com](http://www.intelligent-energy.com)**

© Intelligent Energy Limited 2024. The Intelligent Energy name, logo, and other trade brands/names referenced herein are trademarks or registered trademarks of Intelligent Energy Ltd or its group companies, whether or not they are used with trademark symbol "TM" or "®".

Disclaimer: The information contained in this publication is intended only as a guide and is subject to change as a result of the constant evolution of Intelligent Energy's business and its technology. This publication and its contents (i) are not definitive or contractually binding; (ii) do not include all details which may be relevant to particular circumstances; and (iii) should not be regarded as being a complete source of information. To the fullest extent permitted by law, Intelligent Energy offers no warranty as to the accuracy of the content of this publication, shall not be liable for the content of this publication and no element of this publication shall form the basis of any contractual relationship with a third party or be used by any third party as the basis for its decision to enter into a contractual relationship with Intelligent Energy. Published by: Intelligent Energy Ltd, Charnwood Building, Holywell Park, Ashby Road, Loughborough LE11 3GB (Registered in England with company number: 03958217). Printed March 2024. All information correct at time of going to print. 75984-IE-BR-202304